

Key Benefits:

- Simplify distributed backups for improved redundancy and less admin work.
- Leverage current network assets to share tape libraries easily, no costly upgrades needed.
- Enhance enterprise IT with a scalable, risk-mitigating solution for better agility and reliability.

ATTO XstreamCORE 8100T



10Gb iSCSI to 12Gb SAS Tape Bridge

Backup and Restore your dynamic corporate assets with Quantum Tape Storage over your Ethernet network.

- Leverage your existing Ethernet network to fuel backup and recovery workflows across the organization
- Eliminate unwanted complexity and roadblocks associated with direct-attached configurations
- Deploy Quantum Scalar and Superloader Tape libraries as a shared asset on a secured Ethernet network
- Arm your establishment with an intelligent solution while mitigating concerns of cyber threats

ATTO XstreamCORE SKUs

- XCET-8100-TS0 (SFP+)
- XCET-8100-TN0 (RJ45)

Improve Your Backup and Recovery Strategy with Ethernet-Enabled Quantum Scalar® Tape Storage

ATTO and Quantum leverage a purpose-built solution to extend secure, scalable, and simplified Ethernet based backup capabilities to SAS Tape Libraries.

In today's hybrid IT landscape, managing large, unstructured datasets across diverse environments poses a significant challenge for organizations. Tape storage provides a secure and cost-effective solution by centralizing long-term data storage and enhancing recovery speed. This ensures data availability and business continuity in the face of disruptions.

Known for being the most secure tape solution on the market, Quantum Scalar Tape Libraries offer efficient, intelligent, and secure LTO tape storage for data backup and recovery, archiving, and long-term retention. Quantum Scalar Tape Libraries offer modular designs, enabling easy expansion and performance upgrades while reducing costs through efficient space utilization, proactive diagnostics, and automated monitoring.

Quantum's partnership with ATTO brings customers the most versatile, scalable, and easy-to-deploy Ethernet-enabled tape storage solution available. ATTO XstreamCORE 8100T allows enterprises to tackle backup and recovery directly using Ethernet with Quantum tape storage. Data backups originating from across the organization can be consolidated into a single backup repository to ensure availability, security, and recoverability with improved access to tape storage.

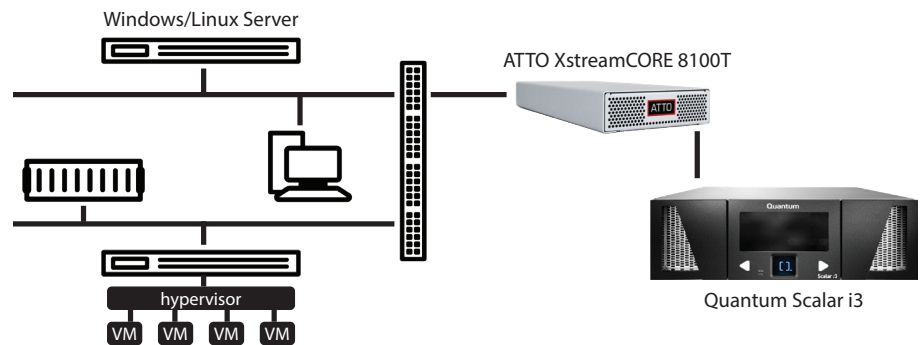

Advancing Data Protection with Intelligent Connectivity

At ATTO, we are redefining the storage landscape by enhancing data mobility and analytics through our pioneering storage bridging and network connectivity solutions. Our technology equips businesses to efficiently analyze backup data, adapt to changing workloads, and achieve robust business continuity and recovery, all while keeping costs and complexity in check.

Advancing Data Protection with Intelligent Connectivity (cont'd)

XstreamCORE 8100T intelligent bridges seamlessly integrate tape storage into modern hybrid IT environments, offering a more flexible and scalable alternative to the traditional direct-attached storage model. It does this, without additional costs or complexity, by enabling network shareability of SAS tape libraries over an existing Ethernet infrastructure.

A complete, integrated data storage infrastructure, 8100T optimizes data management, streamlines movement across the data pipeline, and helps to protect the inherent value of data. It facilitates the creation of a secure, unified data system while streamlining the control of backup and archiving for both file and object storage, even in virtualized environments.

Staying Ahead of Current and Future Threats

Quantum Tape Libraries provide scalable, cyber-resilient storage from small setups to large-scale racks, suitable for all sizes of organizations. They feature dense, reliable hardware and the advanced Scalar Security Framework for enhanced management, monitoring, and ransomware defense. With strict access controls, data protection features like logical tape blocking, and proactive system alerts, they ensure data security and integrity against cyber threats.

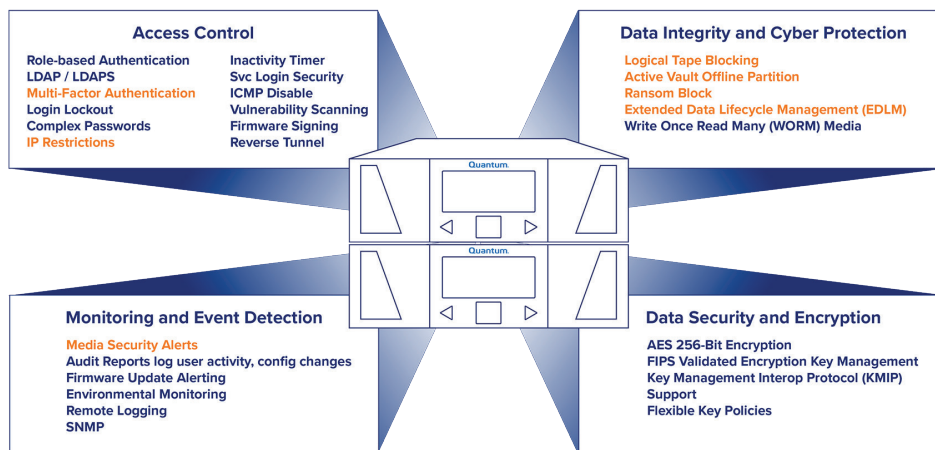

Orange indicates a feature that is unique to Quantum Scalar® Tape Systems.

Businesses can quickly back up large amounts of valuable data to Quantum tape systems over Ethernet using XstreamCORE 8100T. The more efficient and thorough the backup, the better prepared an organization is to recover from disaster.

Additionally, the 8100T enhances security with features like device login and authentication, ensuring your data is not just stored but also protected, aligning with Quantum's goal of safeguarding vital business information.

Certified Compatibility with the Following Quantum Tape Libraries:

Storage Device	Drive Type
Quantum SuperLoader 3	LTO 7 HH, LTO 8 HH, LTO 9 HH
Quantum Scalar i3	LTO 7 HH, LTO 8 HH, LTO 9 HH
Quantum Scalar i6/i6H	LTO 9 FH

Quantum Corporation

Quantum delivers end-to-end data management solutions designed for the AI era. With over four decades of experience, our data platform has allowed customers to extract the maximum value from their unique, unstructured data. From high-performance ingest that powers AI applications and demanding data-intensive workloads, to massive, durable data lakes to fuel AI models, Quantum delivers the most comprehensive and cost-efficient solutions. Leading organizations in life sciences, government, media and entertainment, research, and industrial technology trust Quantum with their most valuable asset – their data. Quantum is listed on Nasdaq (QMCO).

For more information visit www.quantum.com.

ATTO Technology

For over 35 years, ATTO Technology has been a global leader across Enterprise IT, Datacenter, and Media & Entertainment markets, specializing in network and storage connectivity and infrastructure solutions for the most data-intensive, mission critical, and high-performance computing environments.

Interoperability Information

1. Visit Quantum Compatibility Guide. <https://www.quantum.com/en/service-support/compatibilityguides/software-compatibility-guide/>
2. Select the filter "Tape Enablers".
3. Choose "ATTO" as the vendor and select the appropriate product model to view the certification report.

More Information

ATTO Sales: +1.716.691.1999

www.atto.com/products/xstreamcore-intelligent-bridges/xstreamcore-intelligent-bridges-for-ethernet
www.atto.com/howtobuy

Quantum Sales: +1 800.677.6268

Quantum Federal Government Solutions: +1 800.881.2296

www.quantum.com/en/products/tape-storage
www.quantum.com/en/partners/request-form